

Civil engineering

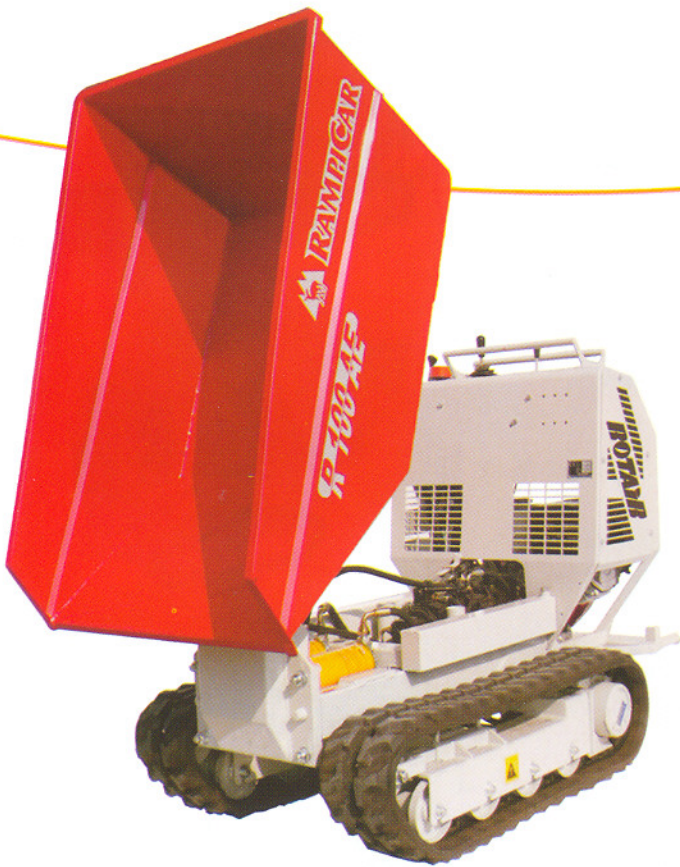
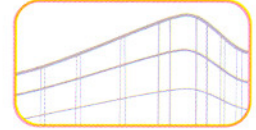

# RAMPICAR R100 / R100 PLUS

IMBATTIBILE NELLE PRESTAZIONI, MANEGGEVOLE NELL'UTILIZZO!  
TRASMISSIONE IDROSTATICA

IMPECCABLE PERFORMANCE AND OPERATIONAL EASE!  
HYDROSTATIC TRANSMISSION



# ROTAPLUS®

TECHNOLOGY AND ENGINEERING SOLUTIONS

# RAMPICAR R100 / R100 PLUS

CARATTERISTICHE TECNICHE TECHNICAL DATA		R100	R100 Plus
Portata utile max a pieno carico Max working capacity at full load		850 Kg 1874 lbs	850 Kg 1874 lbs
Capacità di carico Loading capacity	mc. 0,38 (con cassone tipo dumper) 100,4 gUS (with dumper type body)	mc. 0,38 (con cassone tipo dumper) 100,4 gUS (with dumper type body)	mc. 0,38 (con cassone tipo dumper) 100,4 gUS (with dumper type body)
Peso carro base Weight of undercarriage		420 kg 926 lbs	500 kg 1102 lbs
Motorizzazione Engine details	Honda GX 390 13 HP 4 tempi, benzina Honda GX 390 13 HP 4 stroke, gasoline engine	Kubota Z602 13,5 HP, diesel Kubota Z602 13,5 HP, diesel engine	
Pendenza superabile Max slope		35° 70%	35° 70%
Trasmissione Drive		Idrostatica Hydrostatic	Idrostatica Hydrostatic
Velocità Speed range		0-4,2 km/h From 0 to 2,6 miles/hour	0-3,8 km/h From 0 to 2,4 miles/hour
Ribaltamento del cassone Body tilting		Idraulico Hydraulic	Idraulico Hydraulic
Comandi Controls		mono joystick mono joystick	mono joystick mono joystick
Dispositivo frenante Braking device		Idrostatico al rilascio dei comandi Hydrostatic on control release	Idrostatico al rilascio dei comandi Hydrostatic on control release
Portata ausiliaria olio Oil delivery for auxiliary accessories		-	18 lt/min - 180 bar 4,8 gUS - 2610 psi
Raffreddamento circuito idraulico Hydraulic circuit cooling		-	Di serie Standard

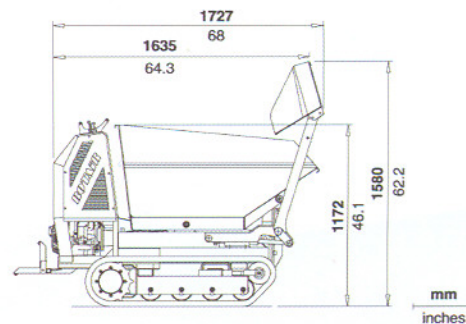
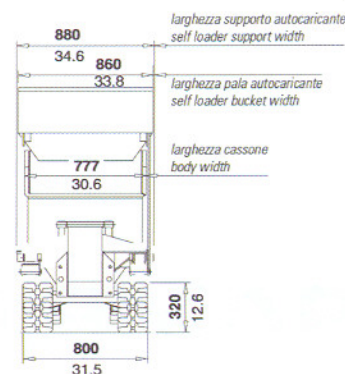
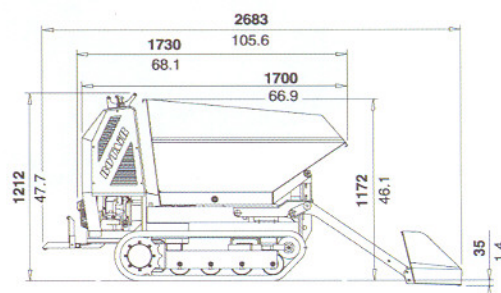

## Prestazioni, robustezza e produttività che non temono confronti!

Peculiarità e punto di forza del minitransporter R 100 è il nuovo sottocarro di ineguagliabile solidità strutturale che incorpora un affidabile e ben collaudata trasmissione idrostatica. Due motoriduttori epicicloidali idraulici garantiscono la massima sicurezza e funzionalità del minitransporter anche in condizioni di impieghi gravosi. Particolare attenzione è stata data al posizionamento ed accesso ai "punti service" ben raggiungibili e protetti. La posizione ergonomica dei comandi che movimentano il minitransporter permette una guida intuitiva e sicura del mezzo anche in condizioni di suolo impervio.

## Number one in terms of performance, sturdiness and productivity!

The most outstanding feature of the new R 100 mini-transporter is its new under-trailer element, which is extremely sturdy and incorporates a reliable and tried and tested hydrostatic transmission. It has two hydraulic epicyclic geared motors to ensure the maximum safety and performance of the transporter even under the most demanding conditions. Particular attention has been given to the positioning and access to the "service points" which are easily accessible and protected. The operator-friendly position of the controls which operate the mini-transporter ensure safe and flexible driving even over rough ground conditions.

## Les performances, la robustesse et la productivité qui ne craignent pas la comparaison!

Le nouveau châssis, caractéristique et point fort du nouveau minitransporteur R 100, présente une solidité structurelle inégalable et incorpore une transmission hydrostatique désormais bien éprouvée. Deux motoréducteurs épicycloïdaux hydrauliques garantissent une sécurité maximale et une grande fonctionnalité du minitransporteur, même dans des conditions d'utilisation difficiles. Une attention toute particulière a été portée au positionnement des "points de service", bien accessibles et protégés. La position ergonomique des commandes de déplacement du minitransporteur permet une conduite intuitive, même si le sol est difficilement praticable.

## Prestaciones, robustez y productividad que no temen a las comparaciones!

La peculiaridad y el punto de fuerza del minitransporter R 100 es el nuevo subcarro de inigualable solidez estructural, que incorpora una fiable y bien ensayada transmisión hidrostática. Dos motorreductores epicicloides hidráulicos, garantizan la máxima seguridad y funcionalidad del minitransporter también en condiciones de utilización difíciles. Se ha puesto una particular atención en el posicionamiento y acceso a los "puntos service" que son de fácil acceso y están protegidos. La posición ergonómica de los mandos que mueven el minitransporter, permite pues una conducción intuitiva y segura del vehículo, también en condiciones del suelo inaccesibles.

Ulteriori informazioni sono disponibili a richiesta. Il costruttore si riserva il diritto di modificare senza preavviso le caratteristiche tecniche sopra indicate. • Further information available on request. The manufacturer reserves the right to modify the technical features here mentioned without prior notice. • De plus amples informations sont disponibles sur demande. Le constructeur se réserve le droit de modifier sans préavis les caractéristiques techniques ci-dessus. • Disponemos de más información según demanda. El fabricante se reserva el derecho de modificar sin previo aviso las características técnicas arriba indicadas.

# ROTAIR®

TECHNOLOGY AND ENGINEERING SOLUTIONS

VIA BERNEZZO, 67 - 12023 CARAGLIO (CN) ITALY  
Tel.: +39 0171.619676 Fax: +39 0171.619677  
www.rotairspa.com • info@rotairspa.com